



Quik Stage Inc.
2121 107th Lane NE
Blaine, MN 55449

763-783-7373 Phone
1-877-783-7373 Toll Free
763-783-7366 Fax

Congratulations on the purchase of your quality portable staging system and/or stage accessories from Quik Stage. The following are detailed instructions to assist you in the set-up and assembly of your new staging and related components. Our engineer has designed every component to be assembled with ease and with a minimal amount of labor and tools. Our first and foremost concern is for the safety of anyone working with or using our products, so please take extra time to make sure that the staging system has been assembled correctly before using. **If at anytime you do not understand these instructions or are having difficulty assembling the stage or accessories, you need to contact Quik Stage for immediate assistance toll free 1-877-783-7373 or 763-783-7373.**

Please Read Carefully Before Proceeding:

The equipment described herein is intended to be used in a commercial application and you, the buyer, agree to operate and maintain the equipment for its intended use in a professional and competent manor as per Quik Stage instructions and recommendations. You are responsible for following applicable governmental standards and good commercial practices using professional and competent mechanics and/or assemblers. If at any time, and for any reason, the staging and related accessories cannot be adequately and safely used for its intended use, the buyer agrees not to use the equipment until proper repairs or corrections are made. **Quik Stage assumes or accepts no responsibility for any damage or failure to any of our stage components or injuries to person or persons due to improper installation or maintenance.**

In the unlikely event any of the portable stage or staging accessories arrived damaged, do not attempt installation and contact Quik Stage immediately.

1-877-783-7373 Toll Free
612-868-4447 Cell Jim Feneis
612-968-6789 Cell Chris Feneis

Quik Stage Storage Carts Assembly Instructions:

All 3 models of the vertical deck carts were designed so they can be shipped unassembled to save freight cost. If we did ship this as a welded component, it would take another pallet and cost you a lot more money in shipping cost. In most cases, we will install the casters and all you have to do is install the 2 up rights and 1 cross brace. All of the necessary hardware is included for easy assembly and a 9/16" wrench is required to tighten the Nylock self locking nuts.

(Note: the only time we would not install the casters is if we are short on pallet space as we try to ship everything on as minimal amount of pallets as possible to save you freight expense.)

Storage Carts:

Quik Stage offers a 6, 8, and 10 deck vertical stage deck storage carts (Fig. 1) plus a cart for guardrails. (Fig. 2)

Fig. 1



Vertical Stage Deck Storage Cart

Fig. 2



Guardrail Storage Cart

Below you will find an exploded view of cart as well as included hardware for assembling cart. (Fig. 3 and 4)

Each cart includes the following. It does not matter if you ordered the 6, 8 or 10 deck cart, as all parts are the same for each model except the base frame which depends on what size you ordered. The only exception is the adjustable top brackets are sized to fit each size cart so if you ordered a 6 and 8 deck cart for example, you need to make sure you are using the correct brackets for each cart and they will be marked as such. 8 deck cart brackets are longer with 1 extra adjusting hole.

- 1 base frame. Either 6, 8 or 10 deck
- 4 casters. 2 rigid and 2 swivels. 4 swivels if special ordered
- 2 uprights
- 1 cross member
- 4 adjustable top brackets
- 2 plastic threaded knobs for securing top brackets
- All necessary hardware for assembly
- Assembly time is about 10 minutes per cart even if you are not mechanically inclined.

Fig. 3



Fig. 4



**Exploded View of Stage Storage Cart
Assembly Hardware**

Included Cart

In most cases, storage carts may be shipped with the casters attached. If the cart were shipped without casters installed, the casters and mounting hardware would be packaged in a box. (Fig. 5) The only tools required to install the casters are a 9/16-inch open box wrench and 9/16-inch socket and socket wrench.

Fig. 5



Included Caster Hardware if Applicable

It will be a lot easier if you have two people to assemble carts. As we mentioned above, your cart may or may not have been shipped with the 4 casters attached. If they are attached, proceed to step 2. If not, you need to attach each of the 4 casters. Your cart comes standard with 2 each rigid and 2 each swivel casters.

(if you special ordered 4 swivel casters, it does not matter which corner you start on)

The most important thing is you need to make sure you are putting both rigid casters on one end and the 2 swivel casters on the opposite end as will not work correctly to have 2 of each kind on one side. The easiest way to install the casters is to securely set it on its edge so you can access both the top and bottom of the bolt at one time. You will see a caster plate welded to the bottom of the cart in each corner and it will have 4 holes pre-drilled in them. Each caster has a caster plate located above each wheel also with 4 holes dilled in it and it will match up exactly with the caster plate on the cart. Place the caster up to the caster plate on the bottom side of the cart, line up the 4 holes and insert the 4 each 3/8-16 x1" bolts in each hole from the top of the cart. Next step is to attach the 4 each nylock 3/8-16 nuts to each of the bolts. Once the nuts are attached, securely tighten each nut and bolt using a 9/16" wrench or socket until tight. Once you have all 4 nuts and bolts securely in place, repeat the same process on the opposite side with the matching caster. Once you have both casters attached one end, repeat the same process on the opposite end until you have all 4 casters securely installed making sure all nuts and bolts are fastened tightly. With all 4 casters installed correctly, set the cart on the floor or ground on the casters. (See fig 6 and 7)

Fig. 6

Fig. 7



**Wheel Assembly with Included Hardware.
Assembly**

Installing Wheel

You are now ready to install the 2 uprights and cross member bar. The uprights are the square pipe with a bracket welded on the bottom with 2 holes drilled in them. The uprights attach to the 2 ends of the cart and it does not matter which end you start on as they are the same. The uprights are installed dead center on the end of the cart and you will see 2 holes predrilled that match up with the bracket on the bottom of the upright.

Install the first upright with the 2 each 3/8-16 x 3 inch bolts. Insert the bolts from the outside so the nut is on the inside of the frame. Tighten both nuts securely and repeat the same process on the opposite side. You may not want to tighten the bolts securely until you install the cross member bar just in case of a tight fit. (Fig. 8 and 9)

Fig. 8

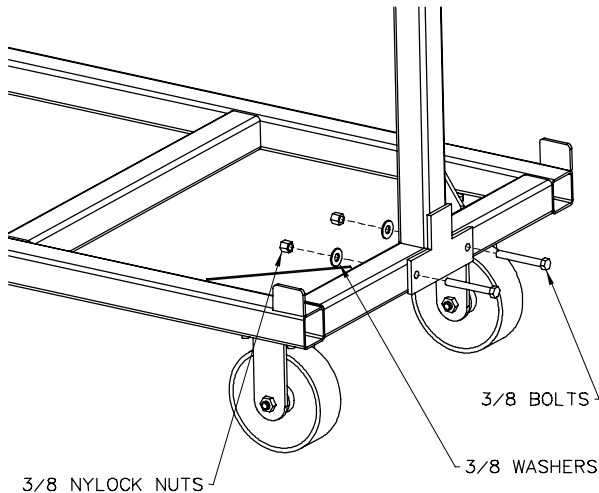

Fig. 9



**Exploded View of Upright assembly
Upright In Place**

Close Up View of

Install the cross member bar into the top of the 2 upright and both ends should slide right in. Again it does not matter which end goes where as they are both the same. Once the cross bar is installed in the uprights, insert a 3/8-16 x 3 inch bolt from the outside with the nuts on the inside on both ends and securely fasten. Once you have both securely fastened, go back and tighten the nuts on the upright on the bottom if you left one side loose as described above. At this time you should have a complete frame with 2 uprights and a cross bar with 2 bolts sticking up on the top. If not, go back to step 1 and 2 and check where you made a mistake. You will see 2 holes drilled on the uprights near the top but you are only using 1 hole to connect

the cross member. The 2nd or bottom hole is only used when you are attaching the optional storage basket. We included an extra bolt and nut to fill the hole for cosmetics only and can be removed and used if you ever order a storage basket. (Fig. 10 and 11)

Fig. 10



Fig. 11



Placing Cross Member Into Upright Provided Hardware

Securing Cross Member with

It is now time to install the top locking L-Brackets which are used to secure the stage decks to the carts. The top brackets are a flat piece of metal with holes drilled in them and one end bent at a 90 degree angle. You will see the 2 bolts sticking up on the top of the cross bar and the top brackets simply install on them with 2 brackets on each bolt. As an example, if you have a 6 deck cart and only purchased only 5 decks, you would put 3 decks on 1 side and 2 on the other. The side with 3 decks requires you to use the end hole of the bracket with the 90 degree angle pointing down on the outside to hold the decks in place. Once you have 2 brackets installed on 1 side, you then proceed to the opposite side and install the remaining 2 brackets in the second hole as you only have 2 decks on that side. 1 of the brackets slides over the top of the other on the bolt so now all you have to do is install the plastic wing nut and tighten until snug with your hand. Repeat the same process on the other end.(Fig. 12 and 13)

Fig. 12



Close Up View Of Locking L-Bracket Rotated For Storage

Fig. 13

View of Locking L-Brackets

The optional storage basket available for storing legs, clamps and miscellaneous stage items is attached to the center tree on both ends. If the vertical cart comes equipped with a storage basket, align the holes in the basket with the holes in the center tree and insert

the 3/8 bolts with washers. Thread the 3/8 nylock nuts on the bolts and tighten with the wrench and socket. (Fig. 14 and 15)

Fig. 14

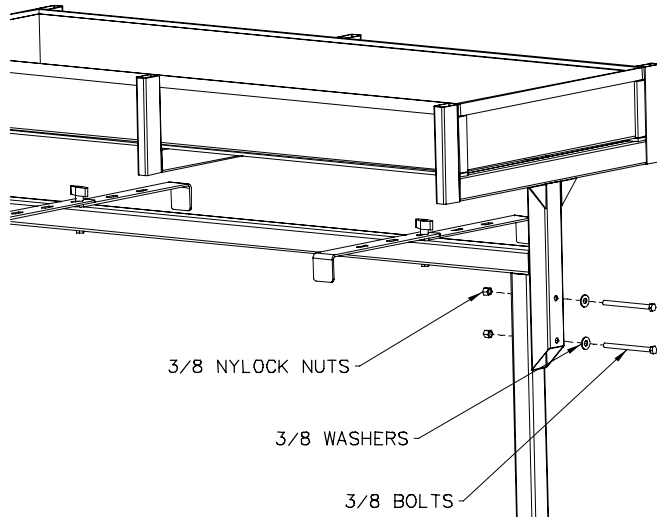

Fig. 15



**Exploded View of Basket Assembly
Cart With Basket**

View of Completed

After the vertical cart has been assembled, it is ready to store decks. Place the first deck on the cart next to the tree, find the appropriate slot in the slotted deck bracket and secure the deck in place on both ends of the deck. More decks can be added by just moving the brackets. When no more decks are to be stored on the cart, tighten the T-knob on the brackets so they do not vibrate loose. (Fig. 16)

Fig. 16



View of Vertical Storage Cart Assembled and with Staging Decks In Place.

If at any time you are having trouble or cannot figure out the installation, please contact Quik Stage immediately at toll free 1-877-783-7373 or e-mail sales@quikstage.com for assistance. Do not use the cart until you have contacted a Quik Stage factory representative. Remember to make sure all nuts and bolts are fasten securely and tighten before using as you are responsible for correctly assembling the cart.